

Product Image

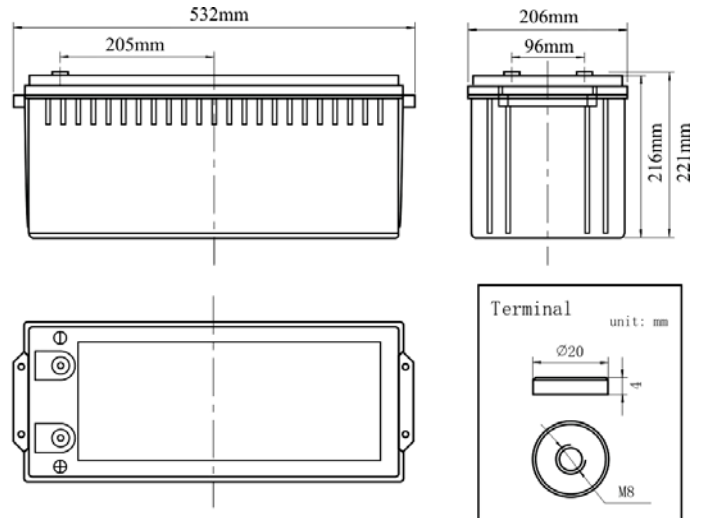

Product Dimensions



Characteristics

| | | |
|---|---------------------------|--|
| Nominal Voltage | | 12V |
| Nominal Capacity (10 hour rate) | | 160Ah |
| Capacity 25°C (77°F) | 20 hour rate (8.88A) | 177.6Ah |
| | 5 hour rate (29.2A) | 146Ah |
| | 1 hour rate (106.4A) | 106.4Ah |
| Internal Resistance | Full Charged Battery 25°C | ≤3.2mΩ |
| Capacity affected by Temperature (10 hour) | 40°C (104°F) | 102% |
| | 25°C (77°F) | 100% |
| | 0°C (32°F) | 85% |
| | -15°C (5°F) | 65% |
| Self-Discharge 25°C (77°F) Capacity | after 3 month storage | 90% |
| | after 6 month storage | 80% |
| | after 12 month storage | 62% |
| Charge (Constant Voltage) 25°C (77°F) | Float | Initial Charging Current Less than 32A Voltage 13.6-13.8V |
| | Cycle | Initial Charging Current Less than 32A Voltage 14.4-14.9V |

Packaging

| | | |
|-----------------------|-----------------|--------------|
| Battery Dimensions | Length | 532mm |
| | Width | 206mm |
| | Height | 216mm |
| | Total Height | 221mm |
| Box Dimensions | Length | 547mm |
| | Width | 220mm |
| | Height | 296mm |
| Quantity Per Box | | 1 PC per box |
| Net weight Per Cell | | 49kg±900g |
| Net weight Per Box | | 49kg |
| Gross Weight | | 49.8kg |

Discharge Constant Current per Cell (Amperes at 77°F 25°C)

| F.V/Time | 5min | 10min | 15min | 30min | 45min | 1h | 2h | 3h | 5h | 8h | 10h | 20h |
|----------|-------|-------|-------|-------|-------|-------|------|------|------|------|-------|------|
| 1.60V | 538.0 | 358.4 | 270.1 | 168.1 | 120.6 | 106.4 | 64.9 | 47.4 | 30.5 | 18.6 | 16.64 | 9.24 |
| 1.65V | 496.0 | 330.4 | 258.9 | 163.6 | 117.4 | 103.6 | 63.7 | 46.6 | 30.1 | 18.5 | 16.48 | 9.15 |
| 1.70V | 504.4 | 336.0 | 247.6 | 159.1 | 114.1 | 100.7 | 62.5 | 45.7 | 29.7 | 18.3 | 16.32 | 9.06 |
| 1.75V | 445.5 | 296.8 | 236.4 | 154.6 | 110.9 | 97.9 | 61.0 | 44.6 | 29.2 | 18.1 | 16.16 | 8.97 |
| 1.80V | 420.3 | 280.0 | 225.1 | 150.1 | 107.7 | 95.0 | 59.5 | 43.5 | 28.8 | 17.9 | 16.00 | 8.88 |

Discharge Constant Power per Cell (Watts at 77°F 25°C)

| F.V/Time | 5min | 10min | 15min | 30min | 45min | 1h | 2h | 3h | 5h | 8h | 10h | 20h |
|----------|--------|-------|-------|-------|-------|-------|-------|------|------|------|------|------|
| 1.60V | 1003.4 | 668.4 | 503.8 | 313.5 | 224.9 | 198.5 | 121.0 | 88.5 | 56.9 | 34.8 | 31.0 | 17.2 |
| 1.65V | 925.0 | 616.2 | 482.8 | 305.1 | 218.9 | 193.2 | 118.8 | 86.8 | 56.1 | 34.4 | 30.7 | 17.1 |
| 1.70V | 940.7 | 626.6 | 461.8 | 296.7 | 212.9 | 187.9 | 116.6 | 85.2 | 55.3 | 34.1 | 30.4 | 16.9 |
| 1.75V | 830.9 | 553.5 | 440.8 | 288.3 | 206.8 | 182.6 | 113.8 | 83.2 | 54.5 | 33.8 | 30.1 | 16.7 |
| 1.80V | 783.9 | 522.2 | 419.8 | 279.9 | 200.8 | 177.2 | 111.0 | 81.2 | 53.7 | 33.4 | 29.8 | 16.6 |

Note The above data are average values, and can be obtained within 3 charge/discharge cycles. These are not minimum values. Cell and battery designs/specifications are subject to modification without notice. Contact **MCA** for the latest information.

Performance Characteristics

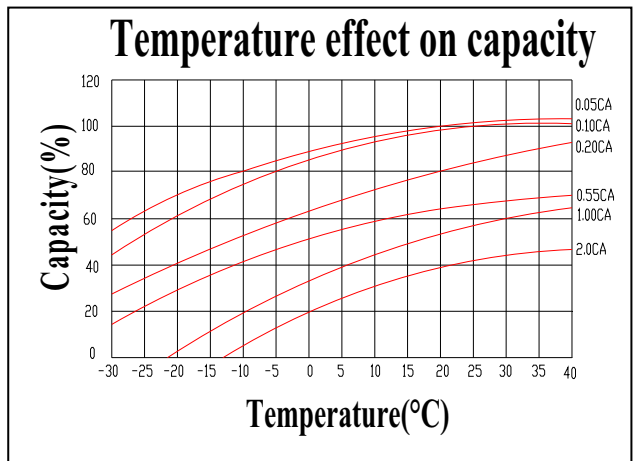
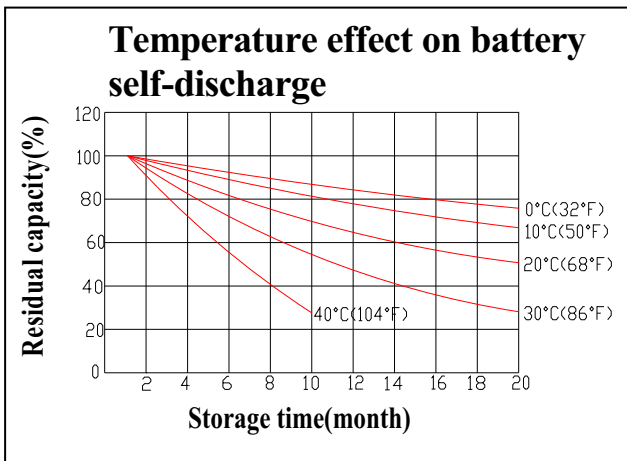
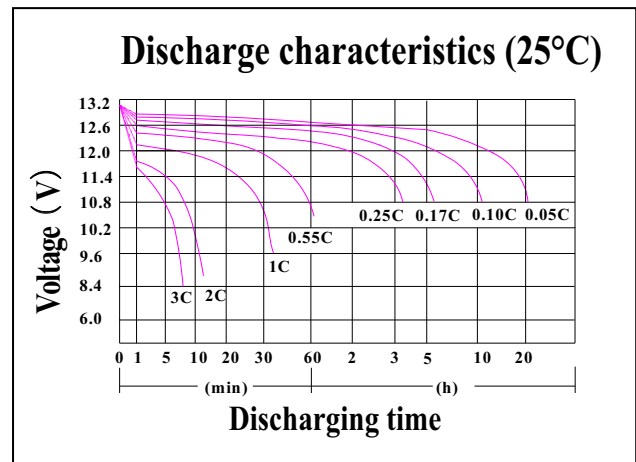
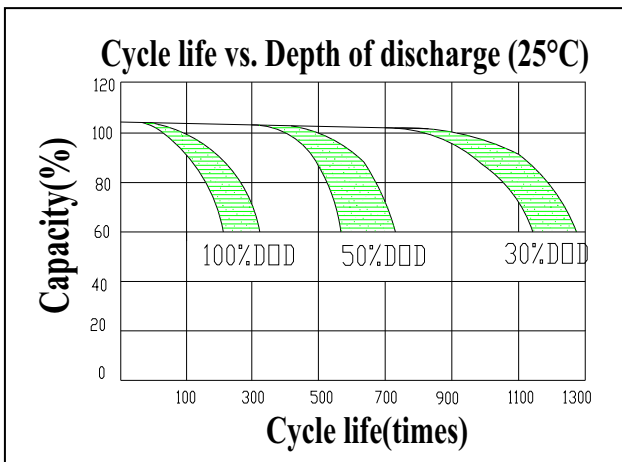
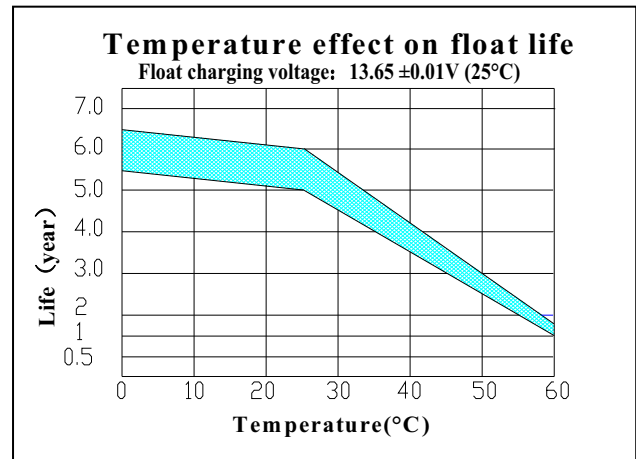
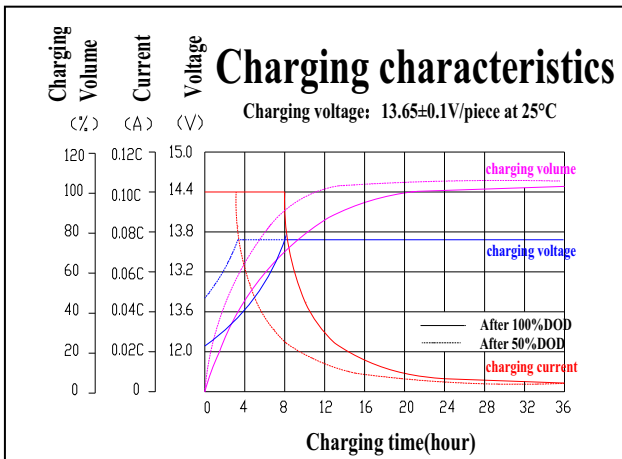

Battery Construction

| Component | Positive plate | Negative plate | Container | Cover | Safety valve | Terminal | Separator | Electrolyte |
|--------------|----------------|----------------|-----------|-------|--------------|----------|------------|---------------|
| Raw material | Lead dioxide | Lead | ABS | ABS | Si-Rubber | Copper | Fiberglass | Sulfuric acid |