

Product Image

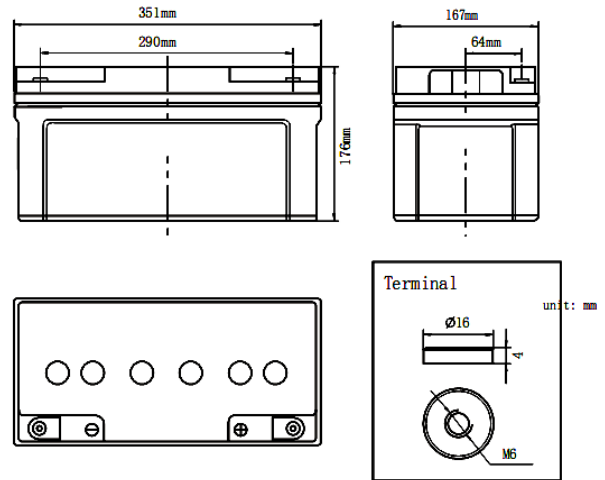

Product Dimensions



Characteristics

Nominal Voltage		12V
Nominal Capacity (20 hour rate)		70Ah
Capacity 25°C (77°F)	10 hour rate (6.3A)	63Ah
	5 hour rate (11.1A)	55.5Ah
	1 hour rate (38.8A)	38.8Ah
Internal Resistance	Full Charged Battery 25°C	≤7mΩ
Capacity affected by Temperature (10 hour)	40°C (104°F)	102%
	25°C (77°F)	100%
	0°C (32°F)	90%
	-15°C (5°F)	70%
Self-Discharge 25°C (77°F) Capacity	after 3 month storage	92%
	after 6 month storage	84%
	after 12 month storage	65%
Charge (Constant Voltage) 25°C (77°F)	Float	Initial Charging Current Less than 14A Voltage 13.6-13.8V
	Cycle	Initial Charging Current Less than 14A Voltage 14.4-14.9V

Packaging

Battery Dimensions	Length	351mm
	Width	167mm
	Height	176mm
	Total Height	176mm
Box Dimensions	Length	212mm
	Width	180mm
	Height	220mm
Quantity Per Box		1 PC per box
Net weight Per Cell		22.5 kg±100g
Net weight Per Box		22.5kg
Gross Weight		23kg

Discharge Constant Current per Cell (Amperes at 77°F/25°C)

F.V/Time	5min	10min	15min	30min	45min	1h	2h	3h	5h	8h	10h	20h
1.60V	166.3	106.0	90.1	57.5	42.3	38.8	24.7	17.3	11.8	7.8	6.9	3.85
1.65V	163.3	104.1	88.5	56.5	41.5	38.1	24.2	17.0	11.6	7.6	6.8	3.78
1.70V	160.3	102.2	86.8	55.4	40.7	37.4	23.8	16.7	11.4	7.5	6.7	3.71
1.75V	157.2	100.2	85.2	54.4	40.0	36.7	23.3	16.4	11.1	7.3	6.6	3.64
1.80V	151.2	96.4	81.9	52.3	38.4	35.3	22.4	15.8	10.7	7.1	6.3	3.50

Discharge Constant Power per Cell (Watts at 77°F 25°C)

F.V/Time	5min	10min	15min	30min	45min	1h	2h	3h	5h	8h	10h	20h
1.60V	320.2	204.1	173.4	110.7	81.4	74.7	47.5	33.4	22.7	14.9	13.3	7.4
1.65V	314.3	200.4	170.3	108.7	79.9	73.3	46.6	32.7	22.3	14.7	13.1	7.3
1.70V	308.5	196.7	167.1	106.7	78.4	72.0	45.8	32.1	21.9	14.4	12.9	7.1
1.75V	302.7	193.0	164.0	104.7	76.9	70.6	44.9	31.5	21.4	14.1	12.6	7.0
1.80V	291.1	185.6	157.7	100.7	74.0	67.9	43.2	30.3	20.6	13.6	12.1	6.7

Note The above data are average values, and can be obtained within 3 charge/discharge cycles. These are not minimum values. Cell and battery designs/specifications are subject to modification without notice. Contact **MCA** for the latest information.

Performance Characteristics

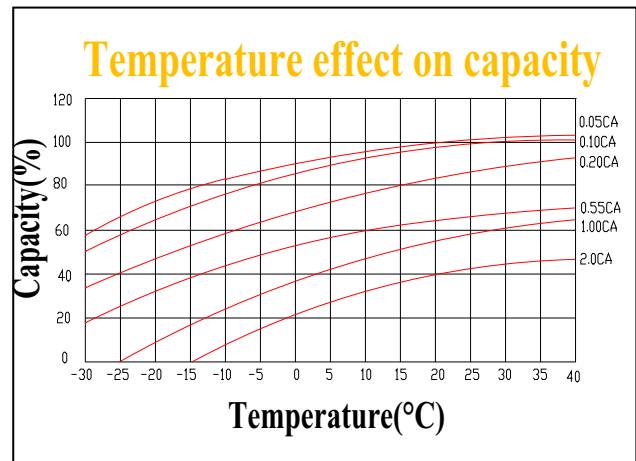
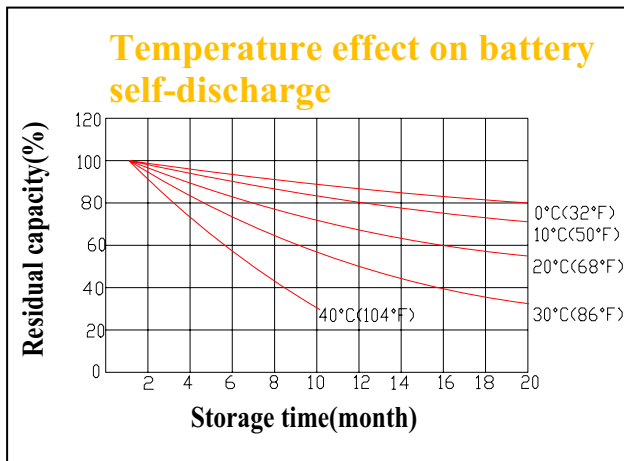
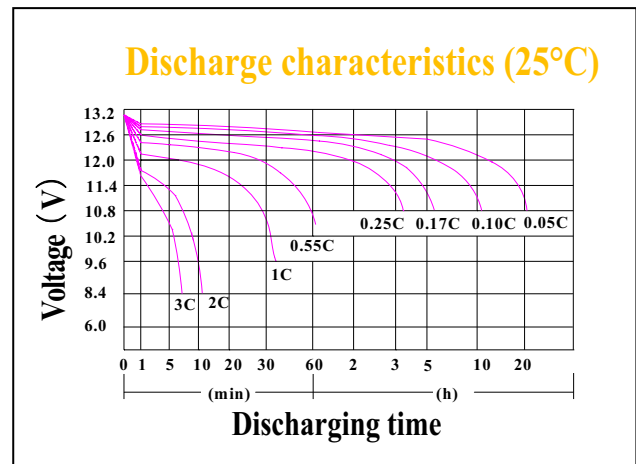
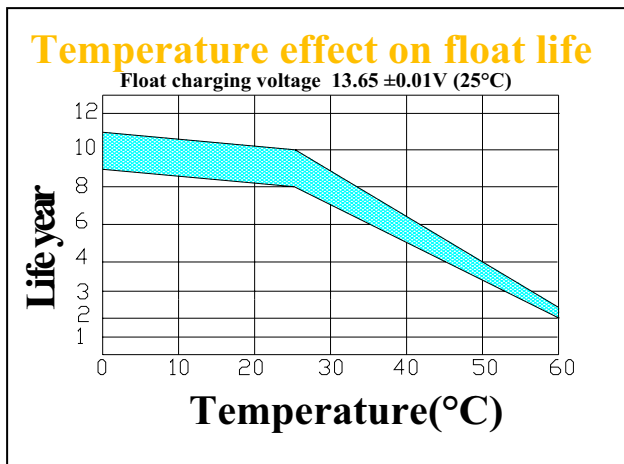
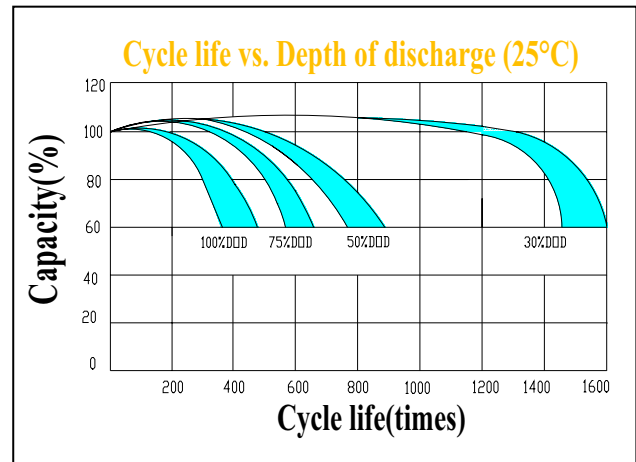
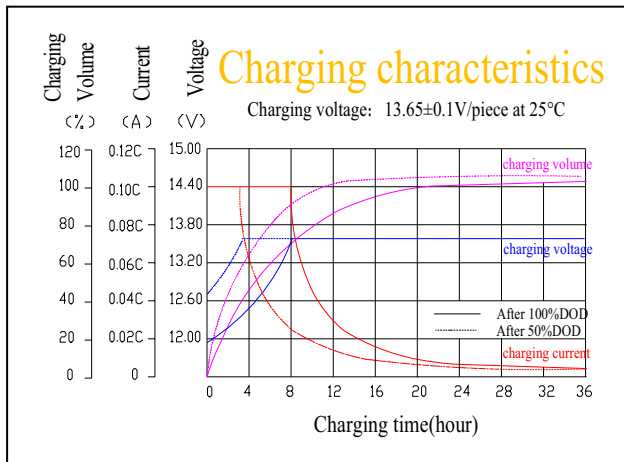

Battery Construction

Component	Positive plate	Negative plate	Container	Cover	Safety valve	Terminal	Separator	Electrolyte
Raw material	Lead dioxide	Lead	ABS	ABS	Si-Rubber	Copper	Fiberglass	GEL